

**PLEASE CHECK WWW.MOLEX.COM FOR LATEST PART INFORMATION**

**Part Number:** [0191640043](#)  
**Status:** **Active**  
**Description:** Perma-Seal™ Step Down Butt Splice for 14-16 AWG to 18-22 AWG Wire

**Documents:**

[Drawing \(PDF\)](#) [RoHS Certificate of Compliance \(PDF\)](#)

**General**

Product Family	Splices
Series	19164
Comments	Step down: 14/16 to 18/22 AWG
Crimp Quality Equipment	Yes
Mil-Spec	N/A
Product Name	Butt - Step Down, Perma-Seal™

**Physical**

Barrel Type	Closed
Insulation	NiAc™
Packaging Type	Bag
Temperature Range - Operating	-55°C to +125°C
Wire Insulation Diameter	5.84mm (.230") max
Wire Size AWG	14, 16, 18, 20, 22
Wire Size mm²	1.94 - 0.38

**Electrical**

Voltage - Maximum	600V
-------------------	------

**Material Info**

Old Part Number	SBA-631
-----------------	---------

**Reference - Drawing Numbers**

Sales Drawing	SD-19164-029
---------------	--------------



Series

image - Reference only

**EU RoHS**

**ELV and RoHS Compliant**  
**REACH SVHC**  
 Not Reviewed  
**Halogen-Free Status**  
 Not Reviewed

**China RoHS**



**Need more information on product environmental compliance?**

Email [productcompliance@molex.com](mailto:productcompliance@molex.com)  
 For a multiple part number RoHS Certificate of Compliance, [click here](#)

Please visit the [Contact Us](#) section for any non-product compliance questions.

**Search Parts in this Series**

19164Series

**Application Tooling | FAQ**

*Tooling specifications and manuals are found by selecting the products below. Crimp Height Specifications are then contained in the Application Tooling Specification document.*

**Global**

Description	Product #
Hand Crimp Tool	<a href="#">0640014500</a>
Hand Crimp Tool, UL Approved	<a href="#">0640017400</a>
Crimp Head for the AT-200™ Pneumatic Hand Tool	<a href="#">0640054500</a>
Power Crimp Tool Head for Prema-Seal™ Terminals 10-22 AWG	<a href="#">0640057400</a>

MATERIAL NUMBER	ENGINEERING NUMBER
191640043	SBA-631

E-19164-029

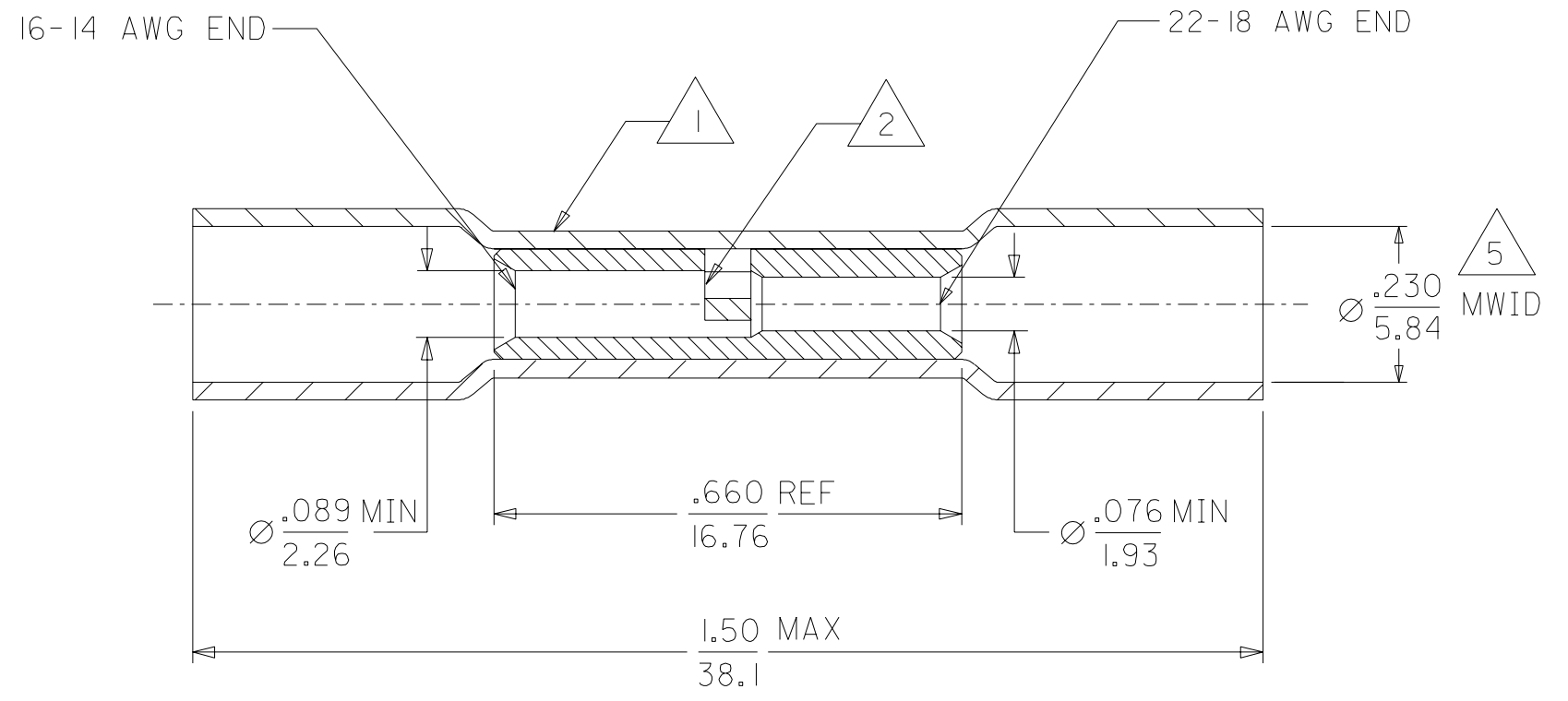
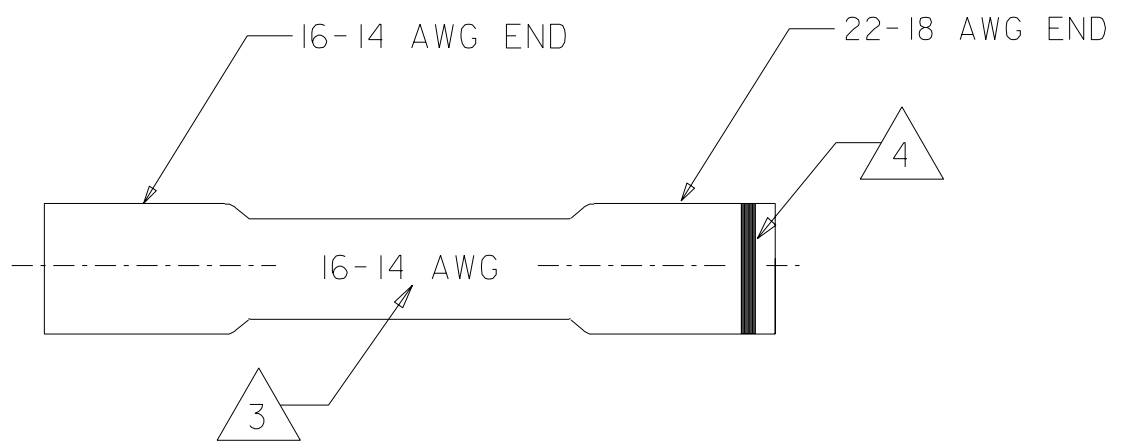

NOTES,

- 1. INSULATION MATERIAL: HEAT SHRINKABLE TUBING WITH HOTMELT INNER LINER, COLOR BLUE.
- 2. SEAMLESS TIN PLATED COPPER TERMINAL.
- 3. PRINTED TEXT IN BLACK .06 HIGH AS SHOWN. DIRECTION CAN BE REVERSED DUE TO MFG PROCESSES.
- 4. RED STRIPE ORIENTATED ON 22-18 AWG END OF CONNECTOR.
- 5. MWID-MAXIMUM WIRE INSULATION DIAMETER.

SALES DRAWING

NEW RELEASE EC NO. ETC2003-0088 DRWN: BRE 03/01/30 CHK: HEB 03/01/30 APPR: RWD 03/01/30	DESCRIPTION MAJOR $\nabla=0$ CRITICAL $\nabla C=0$	QUALITY SYMBOLS		GENERAL TOLERANCES: (UNLESS SPECIFIED)		SCALE NO: NE	DESIGN UNITS <input type="checkbox"/> mm <input checked="" type="checkbox"/> INCH	<input type="checkbox"/> THIRD ANGLE <input checked="" type="checkbox"/> PROJECTION	DIMENSIONS: <input type="checkbox"/> mm <input checked="" type="checkbox"/> INCH <input type="checkbox"/> mm ONLY		SHT REV
		4 PLACES $\pm 0.$ $\pm .$		DRAWN BY & DATE RCM 9/10/28		TITLE: STEP DOWN BUTT SPLICE PERMA-SEAL 16-14 AWG TO 22-18 AWG			MOLEX INCORPORATED		SHEET NO. 1 OF 1
		3 PLACES $\pm 0.$ $\pm .005$		CHECKED BY & DATE JM 9/10/28		MATERIAL NO. SEE CHART			DRAWING NO. SD-19164-029		SIZE B
		2 PLACES $\pm 0.13$ $\pm .01$		APPROVED BY & DATE FP 9/10/28		CAD FILENAME SD-19164-029 .DGN			THIS DRAWING CONTAINS INFORMATION THAT IS PROPRIETARY TO MOLEX INCORPORATED AND SHOULD NOT BE USED WITHOUT WRITTEN PERMISSION.		
1 PLACE $\pm 0.01$ $\pm .$		ANGULAR: $\pm 1/2^\circ$		DRAFT WHERE APPLICABLE MUST REMAIN WITHIN DIMENSIONS							
A	REV										